

# New EZ Flexx50 Bricking Machine

*Newest, most advanced, Bricking Machine on the market*

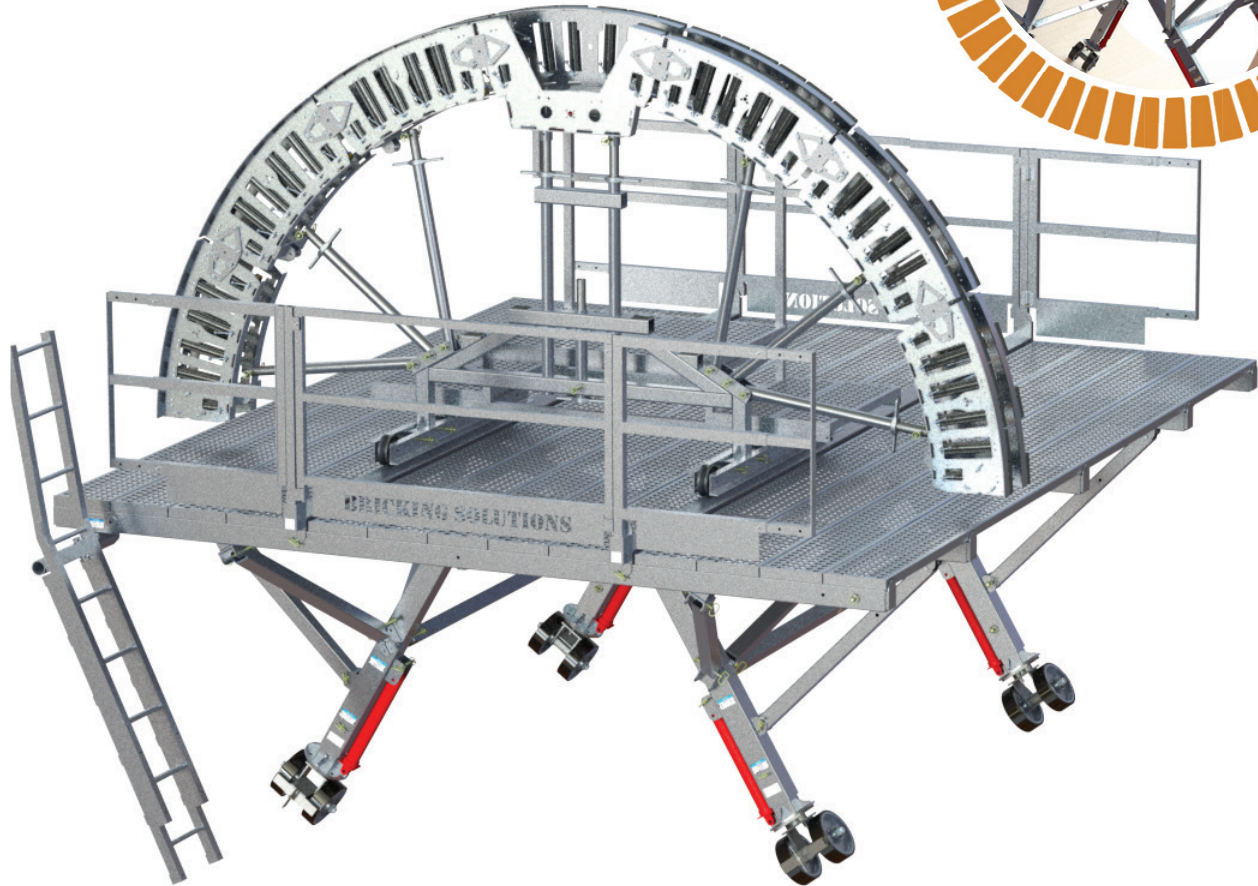
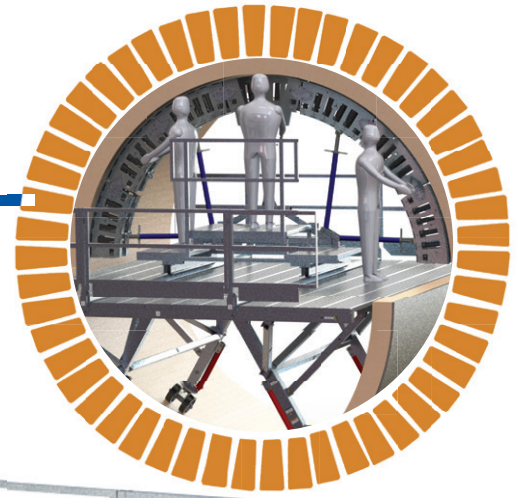

**The EZ Flexx50** is Bricking Solutions' newest and best bricking machine. Bricking Solutions has sold over 1000 bricking machines world wide since the late 1960s. The machine, designed by our professional engineers, is made out of high strength aircraft grade aluminum. The flexible arch allows for easy adjustment inside the kiln for

either minor kiln distortion, or to accommodate conical sections or ovality. The **EZ Flexx50** Bricking Machine comes in any kiln size or range from 3.6m and up, or can be customized to your plant's needs. With a wide variety of additional features for added efficiency, not only is it the safest bricking machine in the industry, it is also the best.

## STANDARD SAFETY FEATURES

- Structural Components 6061-T6 Aluminum
- Load Capacity 4,000 kg (8,800 lb)
- 4.3M (14') Work Platform Length
- Safety Check Valve
- Perf-O-Grip Planking
- Safety Fall Guards
- CE, OSHA and AWS D1.2 Compliant
- Dual Braking System on Arch Trolley

## STANDARD EFFICIENCY FEATURES

- Premium Valve in Base Cylinders
- Dual Master Valves
- Gimbaled Double Wheels
- Refractory Installation Keying Jack
- Cut Away Key Section
- Pin Connections for Fast Assembly
- Adjustments on the fly inside the kiln
- Supplied Spare Parts

### New Machine Design

- Frames and structural components manufactured from 6061-T6 aircraft grade aluminum
- Lightweight aluminum Perf-O-Grip planking for secure footing and less build up
- Lightest total weight in the industry
- Components fold for easy storage
- Symmetrical part design with pin connections for fast and easy assembly



### Load Capacity / Deck Length

- Standard 4,000 kg (8,800 lb) load capacity and 4.3M (14') work platform. Allows for 2 pallets of bricks (1,540 kg) plus men and equipment. Highest load capacity in the industry

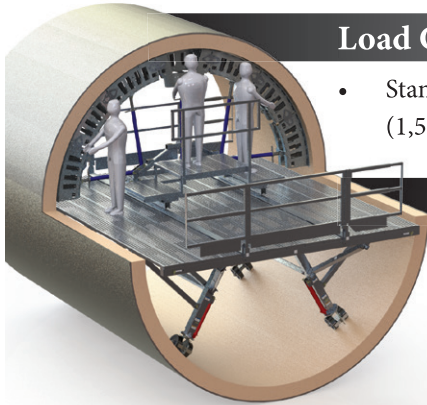

### New Arch Trolley Design

- Simple jack screws allow for easy adjustment of distance between arch and shell
- Ergonomic stair step design is incorporated in the arch trolley and moves along a rail system the entire length of the work platform
- Arch trolley is designed with a dual point breaking system

### Keying Access

- Ergonomic Cut-Away Keying Section, exclusive to Bricking Solutions, gives the Key Mason easy access to down-kiln arch giving a clear view for critical key brick installation
- Refractory installation keying jack is included with every machine



### Arch Design

- Segmented double arch, screw jacks and arch hinges for adjustments on the fly
- Only bricking machine in the industry that fully adjusts inside the kiln for distortion and tapers
- Engineered cut-outs incorporated into arch panels for the lightest arch in the industry

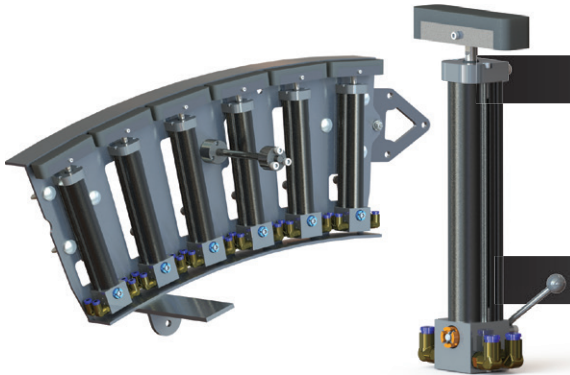

### New Cylinder Design

- Pneumatic valve in base cylinders with push-lock nickel plated brass fittings
- Articulating large rubber bumpers
- Exposed cylinders design allows for less than 10 minute change out
- New cylinders are field repairable

### Dual Master Valves

- Independent operation of cylinder or simultaneously controlled on both arches

### Options / Upgrades

- 6,000 kg (13,200 lb) Load Capacity / 5.2M (17') long work platform- Allows for 3 pallets of brick, plus crew and tools
- Pneumatic powered refractory keying jack - Fingertip controlled
- Shim Driver - Includes 4 shanks and 2 heads
- 20' Steel storage container - built in custom racks for lifetime storage of the bricking machine
- Tool trays - extra storage on arch fall guards
- Ultra-bright LED lights for up or down kiln
- Movable Work table - for key bricks or tools
- Up-kiln ladder - allows for dual access on the bricking machine
- On-site commissioning by trained technician